

AL/1 - OIL LEVEL DIPSTICKS, PUSH-FIT
ONE SEAL

ALS/1 - OIL LEVEL DIPSTICKS, PUSH-FIT,
ONE SEAL AND BREATHER HOLE



S = Breather hole
OR = O-Ring



FLEX MODEL

-Push-fit dipstick with eye-handle made from steel, round section, phosphated surface.

-Handle produced from thermoplastic material (Polyamide 66) featuring excellent mechanical resistance, dimensional stability and shocks resistance; max working temperature **100°C/212 °F**.

-Delivered with one O-Ring seal (models AL-S/1) or with two O-Rings (models AL-S/2) in NBR 70 Shore durometer.

AL/2 - OIL LEVEL DIPSTICKS, PUSH-FIT
TWO SEALS

ALS/2 - OIL LEVEL DIPSTICKS, PUSH-FIT
TWO SEALS AND BREATHER HOLE

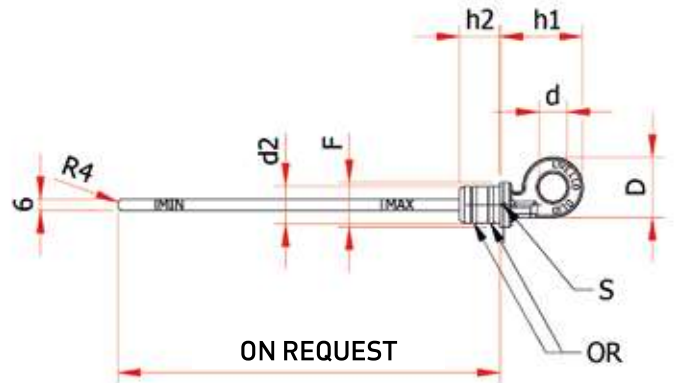
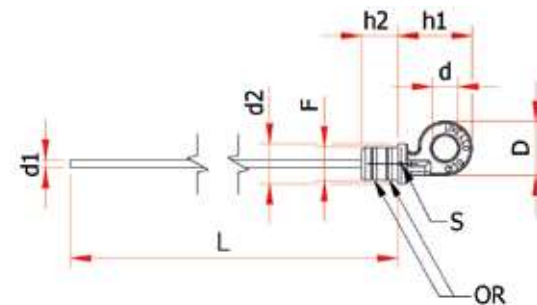
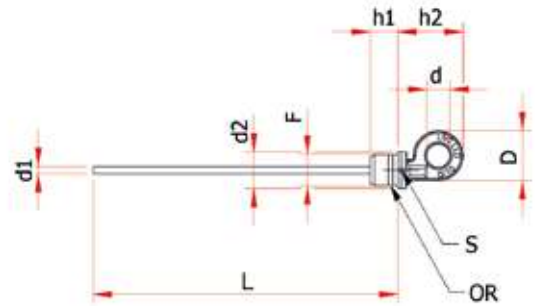

ON REQUEST

-Model ALS is provided with a breather hole located on to the shoulder of the dipstick handle.

-For quantities of at least 250 pcs the dipstick can be cut at custom length complete with MIN-MAX level markings.

-Special model FLEX: a blade-style flexible dipstick, phosphated surface, can be provided upon request for adequate quantities; laser inscription and MIN-MAX level marking can be provided as well. The flexible dipstick is suitable for applications that require a special shaped profiles to be followed.

	Code	Ø F	D	d	d1	d2	h2	h1	L	
	AL/1/14	ALS/1/14	14	27	13	4	17,9	13	34	183
	AL/1/18	ALS/1/18	18	32	14	5	23,6	17	45	196
	AL/1/20	ALS/1/20	20	32	14	5	23,6	18	44,5	196
	AL/1/30	ALS/1/30	30	32	14	5	33,6	17	45	194
	AL/2/12	ALS/2/12	12	27	14	4	18	20	36	200
	AL/2/14	ALS/2/14	14	27	13	4	18	20	34	183
	AL/2/18	ALS/2/18	18	32	14	5	23,5	21	44	196
	AL/2/20	ALS/2/20	20	32	16	5	23,6	21	44	196