

AL(S)/1 – OIL LEVEL DIPSTICK, PUSH-FIT ONE SEAL

AL(S)/2 – OIL LEVEL DIPSTICK, PUSH-FIT TWO SEALS

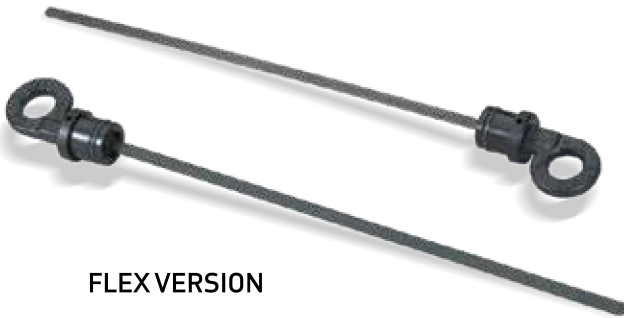

FLEXVERSION

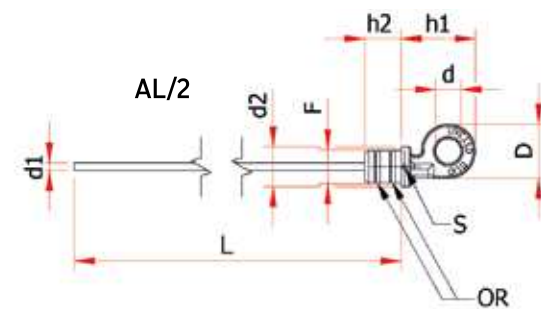
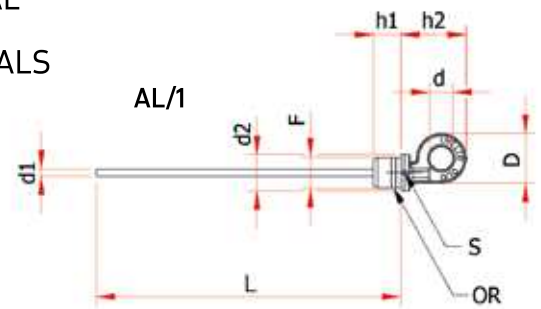

S = Breather hole
 OR = O-Ring

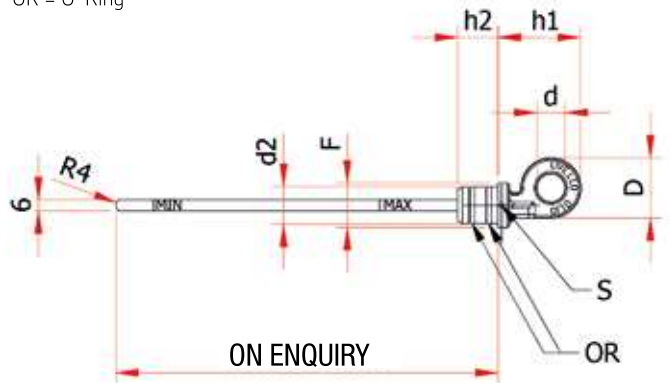

Push-fit dipstick with eye-handle, ensuring high mechanical resistance at both low and high temperatures, dimensional stability and shocks resistance.

- **Material:** Polyamide PA66.
- **Sealing:** O-ring NBR 70 Shore.
- **Maximum working temperature:** 100°C/212°F.
- **Breather:** model ALS provided with one or two breather holes located on to the shoulder of the dipstick handle.
- **Level dipstick:** cylindrical section with zinc steel phosphated surface.

Special versions

- **Level dipstick:** customizable length with MIN-MAX notches.
- **Flex:** blade-style level dipstick with zinc phosphated surface, customizable laser inscriptions. Flexible dipstick is suitable for applications that require special shaped profile.

Cod.	Ø F	D	d	d1	d2	h2	h1	L	Pack.
AL/1/14 ALS/1/14	14	27	13	4	17,9	13	34	180 ±5	100
AL/1/18 ALS/1/18	18	32	14	5	23,6	17	45	180 ±5	100
AL/1/20 ALS/1/20	20	32	14	5	23,6	18	44,5	180 ±5	100
AL/1/30 ALS/1/30	30	32	14	5	33,6	17	45	190 ±5	100
AL/2/12	12	27	14	4	18	20	36	180 ±5	100
AL/2/14 ALS/2/14	14	27	13	4	18	20	34	195 ±5	100
AL/2/18 ALS/2/18	18	32	14	5	23,5	21	44	195 ±5	100
AL/2/20 ALS/2/20	20	32	16	5	23,6	21	44	180 ±5	100