

LSF - FLOAT LEVEL SWITCH WITH FLANGE

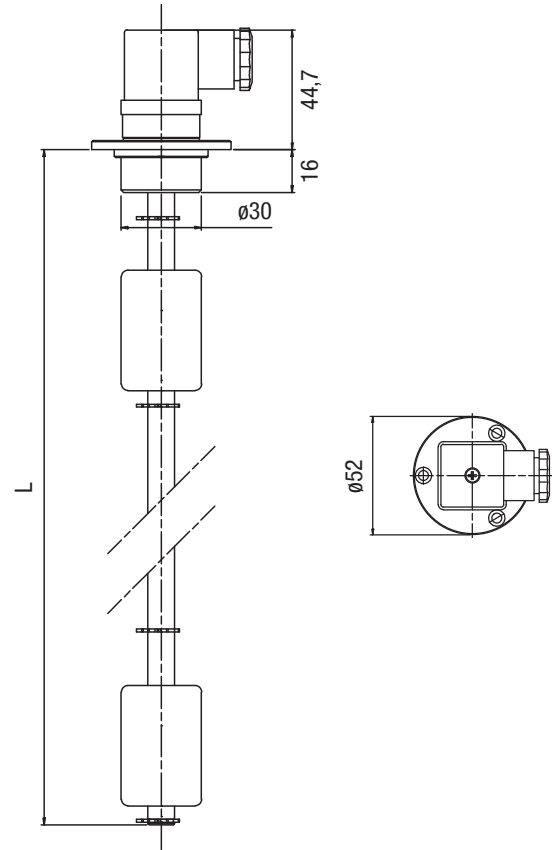
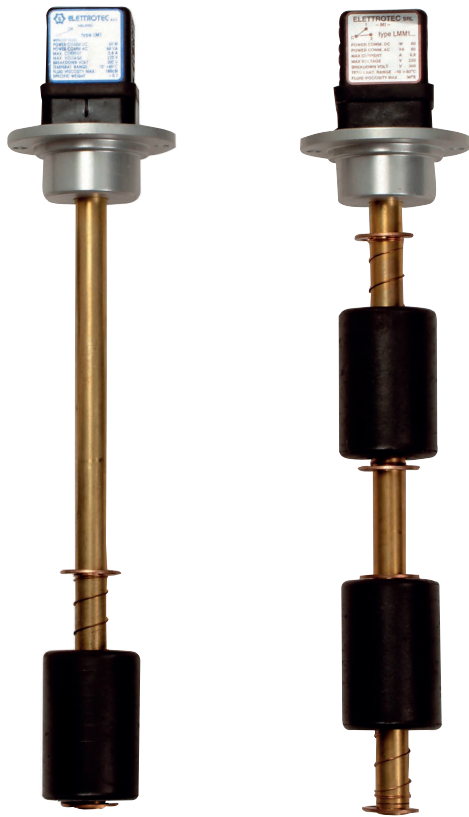

Level switch particularly suitable for hydraulics, lubrication plant, water treatment, industrial vehicles, fluid stocking, cleaning machines and equipment. The hermetically sealed reed switch housed inside the stem is actuated by a magnetic field created by a magnet equipped float. As the float rises and lowers with liquid level, the magnetic field passing the switch in the stem causes the switch to either open or close. Executions specifically approved R.I.N.A.

Flange: anodized aluminum.

Stem: in brass and stop rings in bronze.

Floating element: NBR.

Maximum working pressure: 10 bar.

Maximum working temperature: 80°C (176 F).

Tube length: customizable from 100 mm to 1500 mm.

Models

One or two floating elements.

One or two actuation points NO or NC.

Integrated thermostat set at 40°-50°-60°-70°-80° C

NO or NC.

Max. fluid viscosity	150 cSt
Fluid specific gravity	≥ 0,7 kg/dm ³
Max voltage	220 Vac
Rating power	30 W
Max current	0,5 A

ORDERING CODE

